

DALI EASY IR CI

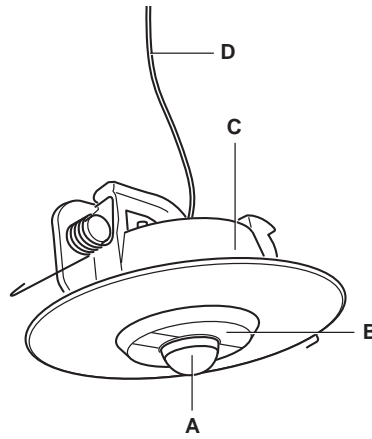

Infrared receiver for ceiling installation Fitting instructions

Description



Function and application

The infrared receiver in conjunction with a DALI EASY RMC remote control is used for the adjustment and functional control of the DALI EASY III and OT EASY 60 II control units.

The infrared receiver is suitable for ceiling installation or can optionally be surface-mounted with an adapter ring.

Function

The infrared receiver converts the digitally coded infrared signals of the DALI EASY RMC remote control into the corresponding telegrams and transmits them to the connected control units.

Design

The infrared receiver for ceiling installation consists of the following components:

- Infrared sensor (A)
- Inner ball for tilt adjustment (B)
- Housing (C)
- Connection cable (D)

Installation

Safety instructions

The infrared receiver must only be installed and put into operation by a qualified electrician.

The applicable safety regulations and accident prevention regulations must be observed.



WARNING!

Exposed, live cables.

Danger of electric shock!

- Only work on the infrared receiver if it has been de-energised.

CAUTION!

Destruction of the infrared receiver and other devices due to incorrect installation!

- Do not wire the infrared receiver with an external voltage, especially not a mains voltage of 230 V.
- For SELV, provide for adequate insulation against parts that conduct mains voltage.
- Only connect infrared receivers to control units of the type DALI EASY III or OT EASY 60 II.
- Do not exceed the maximum line length.
- Do not route the connection cable together with power supply or lamp lines.

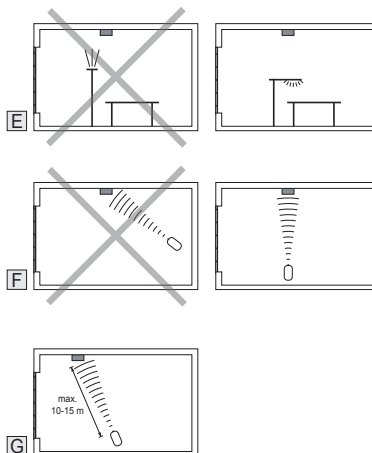

Selecting the installation location

E Avoid exposure to direct light. The installation location should be in a shaded area.

F Line of sight at a steep angle.

G Range of remote control: max. 10 – 15 meters.

III 2009

DALI_EASY_IR_CI_ma0903en_we1.01.indd

OSRAM GmbH
Kunden Service Center
Customer-Service-Center (CSC)

Steinerne Furt 62
86167 Augsburg
Germany

Tel : +49 (0) 1803 677 - 200
(kostenpflichtig / charges apply)
Fax.: +49 (0) 1803 677 - 202

www.osram.com

www.osram.de



4008321915573

Fitting (cont.)

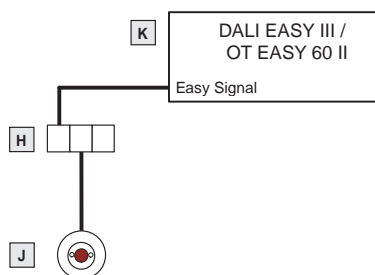
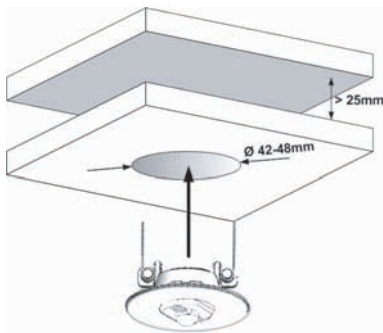

Ceiling installation

- Diameter of installation opening: 42 – 48 mm
- Minimum suspended ceiling distance: 25 mm

Note:

For surface-mounted ceiling installation, use the sensor mounting kit SENSOR KIT (adapter ring, accessories).

Connecting the infrared receiver

Connect the infrared receiver to the control unit or a Y-connector with the connection cable.

Up to 4 infrared receivers can be connected in parallel via Y-connectors.

H Y-connector (optional)

J DALI EASY IR CI infrared receiver

K Control unit

Adjusting the detection area

Tilt the inner ball of the infrared sensor up to 30° in the desired direction (this optimizes the ability to operate the system by remote control from the selected location).

Appendix

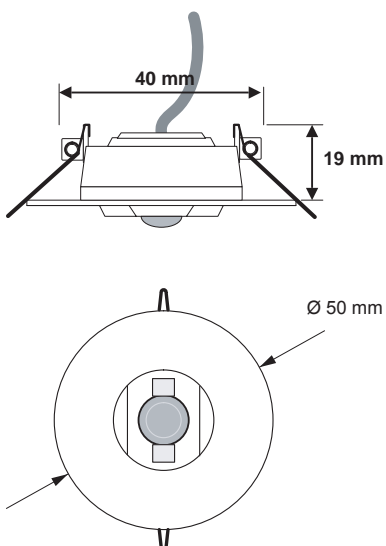

Technical data

Connection	Permanently attached 4-pin modular connection (4p4c) Length: approx. 2 m
Maximum total length of signal line (incl. all connection lines to the control units)	100 m
Operating temperature	0 °C ... +50 °C
Protection type	IP 20
Dimensions (Ø x H)	50 x 25 mm

The CE requirements to 61347-11 are fulfilled. The EMC requirements to EN 61547 are fulfilled.

CE Conformity with the relevant EU directives is confirmed by the CE symbol.