

Operation instructions

I / 2005

Radio receiver module Touch DIM RC



OSRAM GmbH Customer Service Center
Albert-Schweitzer-Str.64, 81735 München
Germany

Tel : +49 (0) 1803 677 - 200
Fax. : +49 (0) 1803 677 - 202

www.osram.com

www.osram.de

General

Table of contents

General	Application and function.....	2
	Safety and installation instructions.....	2
Installation	Design and dimensions.....	3
	Wiring diagramm.....	3
Start-up and operation	Training of wall transmitters.....	4
	Untraining /cancelling wall transmitters.....	4
	Operation.....	5
Annex	Notes on radio operation.....	6
	Troubleshooting.....	7
	Technical data.....	8

Application and function

TOUCH DIM RC receiver module enables two luminaire groups with OSRAM control gear featuring the Touch DIM function to be remote-controlled. The module receives radio telegrams from wall transmitters and converts them at the output into Touch DIM signals. The wall transmitters are based on piezo technology and generate the necessary transmission energy directly when they are pressed. There is no need for any batteries and the wall transmitters require no maintenance.

The TOUCH DIM RC is designed for installation in luminaires. With the optional installation kit, LMS CI BOX with cable clamp, it can also be mounted as a separate unit, for example in suspended ceilings.

Safety and installation instructions

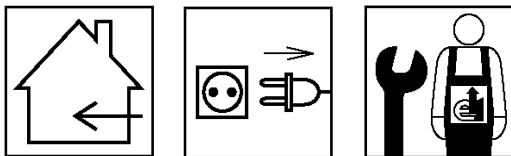

- The unit should be installed and tested only by a qualified electrician.
- Power to the units must be switched off before any work is undertaken.
- The relevant safety and accident prevention regulations must be observed.

The TOUCH DIM RC module is used exclusively for controlling OSRAM control gears or OSRAM transformers with the Touch DIM function. Mains voltage or any other external voltage must not be applied to the Learn, T1 or T2 inputs. The Touch DIM RC module may only be operated on AC voltage. DC operation, for example in conjunction with UPS systems, is not permitted.

Using the equipment for any purpose other than its intended use may lead to damage or destruction.

Installation

Design and dimensions

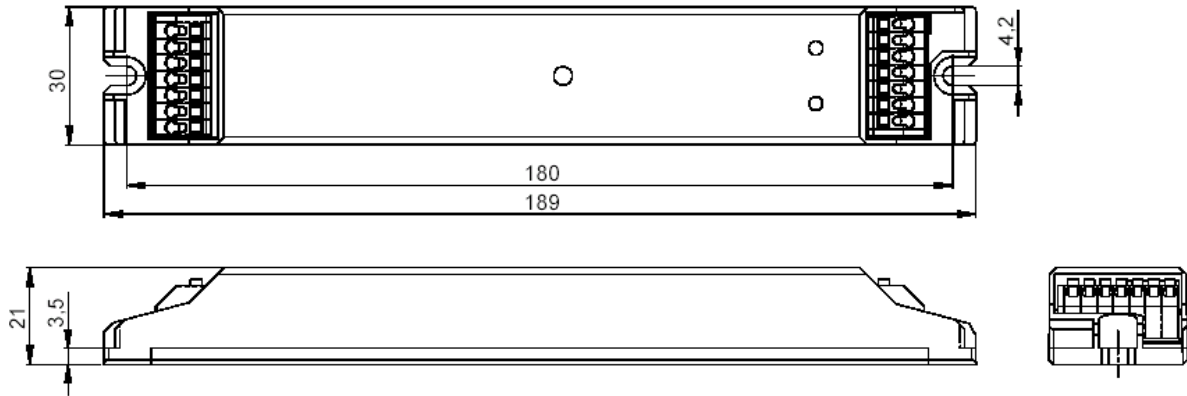

Wiring diagramm

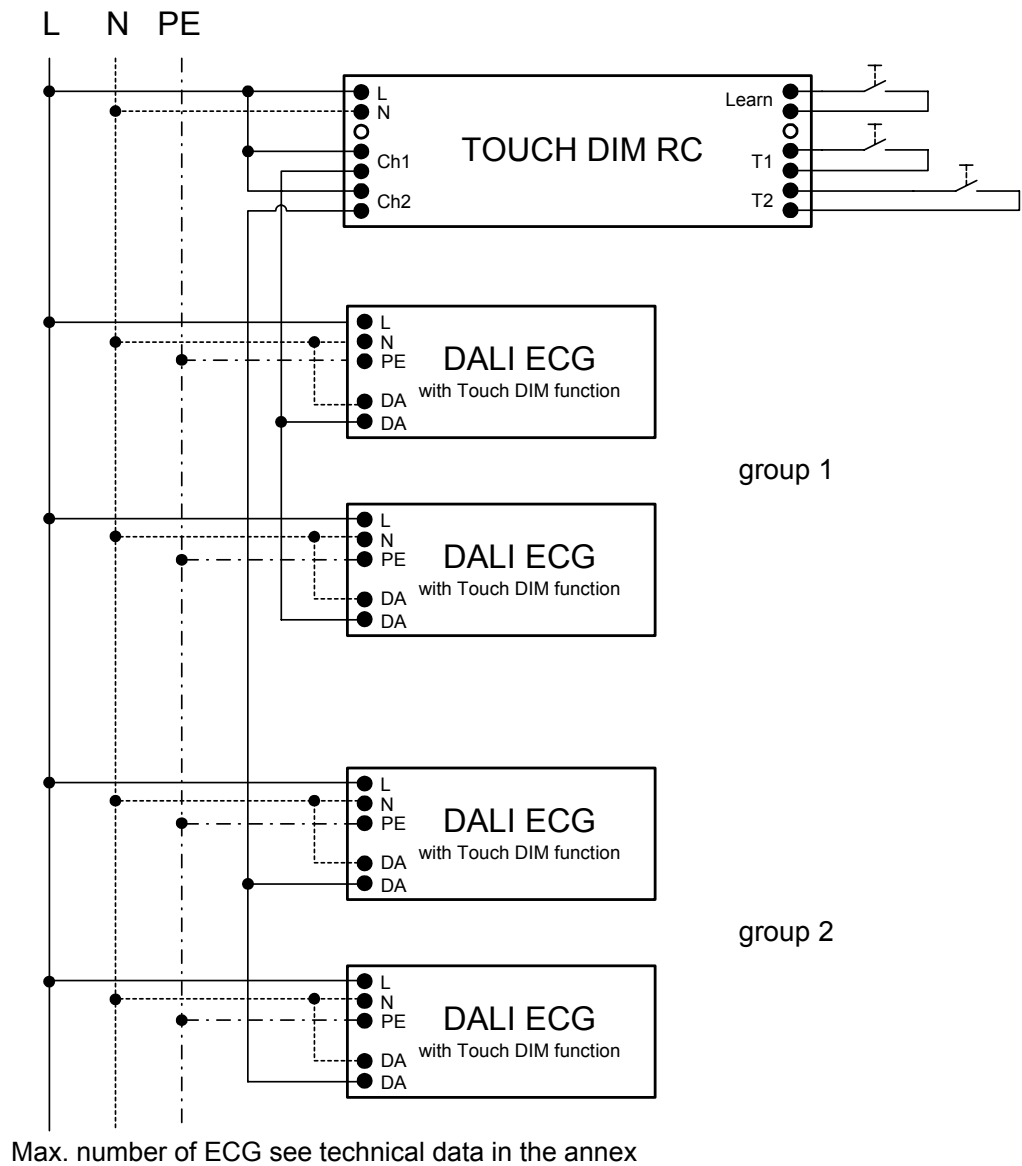

Start- up and operation

Training of wall transmitters

Before the control gear connected to the Touch DIM RC module can be operated, the relevant wall transmitter has to be trained in the receiver.

Hold down the button marked “press to activate learn mode” on the receiver with a suitable tool (such as an insulated screwdriver) until the “Learn mode active” LED starts to flash. Alternatively, this learn mode can be activated by an external switch (make contact) connected to the “Learn” terminals.

Now operate the wall transmitter to be trained. On receipt of a radio telegram, the LED lights up for 4 seconds, then goes out for a further 4 seconds and then continues to flash to confirm that it has been successfully trained. While the LED is flashing further wall transmitters can be trained.

In each case, both channels (= both buttons) of a wall transmitter are trained so that ECGs connected to Ch1 and Ch2 (i.e. Group 1 and Group 2) can be operated. There is therefore no need to train the second wall transmitter channel separately.

The learn mode can be terminated by pressing the “press to activate learn mode” button again or with an external switch connected to the “Learn” terminals. The learn mode is automatically terminated if a wall transmitter has not been operated for 30 seconds.

Untraining /cancelling wall transmitters

Wall transmitters that have already been trained can be easily “untrained”.

This is done through the learn mode. Hold down the button marked “press to activate learn mode” on the receiver with a suitable tool (such as an insulated screwdriver) until the “Learn mode active” LED starts to flash. Alternatively, this learn mode can be activated by an external switch (make contact) connected to the “Learn” terminals.

Now operate the wall transmitter to be cancelled. When a radio telegram is received the LED goes out for 4 seconds and then continues to flash to confirm that the cancel process has been successfully completed. While the LED is flashing further wall transmitters can be cancelled.

In each case, both channels (= both buttons) of a wall transmitter are untrained. There is therefore no need to untrain the second channel separately.

The learn mode can be terminated by pressing the “press to activate learn mode” button again or with an external switch connected to the “Learn” terminals. The learn mode is automatically terminated if a wall transmitter has not been operated for 30 seconds.

Note:

The learning (and unlearning) mode is indicated by the lighting slowly fading up and down in rhythm with the flashing LED. During the learn mode the sensitivity of the receiver module is reduced so that neighbouring transmitters are not trained (or untrained) by mistake. It may therefore be necessary to bring the wall transmitter closer to the receiver to ensure successful training (or untraining).

Start- up and operation

Operation

Each wall transmitter has two channels (= two buttons). One channel acts on output Ch1, the other on output Ch2 of the TOUCH DIM RC module. Two luminaire groups (Group 1 connected to Ch1, Group 2 connected to Ch2) can therefore be operated independently of each other.

Pressing briefly on one of the two channel buttons on the wall transmitter switches the luminaire group connected to the relevant channel on or off. Holding down the button will fade the lighting either up or down. The direction changes each time the button is pressed. If the lighting system is off and the button is held down the luminaires will come on at the minimum dimmer setting and start to fade up.

As an option, the luminaires can be operated with external switches (make contacts) connected to terminals T1 or T2. The switch at T1 operates Ch1, and the switch at T2 operates Ch2.

Note:

All the Touch DIM/Touch DIM Sensor functions of the OSRAM control gear can be accessed. For further information please refer to the documentation for the particular products.

Annex

Notes on radio operation

The installation site for wall transmitters and receivers, the structure of the building and the building materials all have a major impact on the transmission range. The type and number of obstacles between the transmitter and the receiver, sources of interference and signal reflections may reduce the ranges given below quite considerably. If you are in any doubt you should test the transmission range before installing the equipment.

The following transmission ranges are given as guide values:

- In the open air: approx. 300m
- Factories: approx. 100m
- Passageways and corridors: approx. 50m
- Rooms with wooden or plasterboard walls: approx. 30m, penetration of up to 7 walls
- Rooms with brick or breezeblock walls: approx. 20m, penetration of up to 3 walls
- Rooms with reinforced concrete walls: approx. 10m, penetration of one wall

Annex

Troubleshooting

The luminaire is not working. *Possible causes:*

- There is no power.
Check the power connections.
- The lamps are faulty.
Replace them.
- The luminaire has been switched off by the wall transmitter.
Switch the luminaire on.

The luminaire is not reacting as expected to switch operations. *Possible cause:*

- The wall transmitter has not been trained.
Train the wall transmitter as described in the Start-up section.
- The receiver module is too far away from the wall transmitter.
Reduce the distance between the receiver and the wall transmitter
- The switch is being pressed too long.
Please note: Hold down the switch to change the brightness only until the luminaire reaches the brightness level you want. For all other functions, just briefly press the switch.

Annex

Technical data

Operating voltage:	220-240 V/50 to 60 Hz
Current input:	approx. 9 mA
Power consumption:	max. 1.5W
Protection class:	II
Protection type:	IP 20
Ambient temperature:	0 to +50°C
Integrated protection against overheating	reset independently, non replaceable
Frequency band:	868.3MHz
Inputs:	Learn, T1, T2 inputs for floating make contacts
Outputs:	Floating semiconductor relays for Ch1, Ch2, max. 45mA/240V
Number of control gear units per output:	max. 15 QTi DALI ECGs or 15 HTi transformers or 15 QT DALI ECGs
Max. number of wall transmitters:	30

Accessories (Not included)

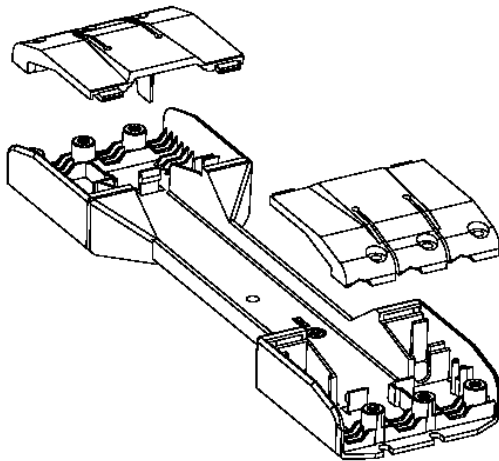

LMS CI BOX

Ceiling installation box for independent mounting of the control unit



The CE symbol signifies compliance with the relevant EU Directives.